

A Repetitively Coded Multicarrier CDMA (RCMC-CDMA) Transceiver for Multiuser Communications

Shang-Ho Tsai[†], Yuan-Pei Lin[‡] and C.-C. Jay Kuo[†]

Department of Electrical Engineering, University of Southern California, CA, U.S.A.[†]

Department of Electrical and Control Engineering, National Chiao Tung University, Hsinchu, Taiwan[‡]

Email: shanghot@usc.edu

Abstract

This work proposes an approximately MAI-free OFDM transceiver, called the repetitively coded multicarrier CDMA (RCMC-CDMA), which uses the CDMA technique to separate different users so that every user can utilize the whole bandwidth and time slots simultaneously. We derive the capacity of the proposed system with multiple receive antennas, and then compare it to the capacity of the generalized MC-CDMA system. Furthermore, the proposed system is robust to timing mismatch between different users so that it is suitable for uplink transmission. Finally, we show that the system has a great potential to mitigate the carrier frequency offset (CFO) problem.

Keywords— Multiaccess OFDM, MC-CDMA, MAI free, uplink asynchronous timing, carrier frequency offset.

I. INTRODUCTION

Multiaccess communications enable several users to transmit data through a common channel [1]. In 1993, the MC-CDMA system was proposed for multiaccess communications [2]. Like the MC systems, the MC-CDMA has the great advantage in combating inter symbol interference (ISI) caused by frequency selective fading channels. MC-CDMA systems can be divided into two groups [3]. One spreads the data streams using a spreading code and then modulates each subcarrier with each chip, *i.e.* spreading in the frequency domain [2], [4], [5]. The other spreads the serial-to-parallel (S/P) converted data stream using a spreading code and then modulates a different subcarrier with each data stream, *i.e.* spreading in the time domain [6], which is often called the MC-DS CDMA system. A generalized MC-CDMA was proposed in [5]. In this scheme, each S/P converted data bit is spread into several chips and then modulates each subcarrier with each chip, where the frequency separation is maximized to achieve the frequency diversity. Although the MC-CDMA spreads the bits using orthogonal codes to ensure orthogonality, the orthogonality may however be destroyed at the receiver due to frequency selective fading, thus leading to multiaccess interference (MAI). The MAI problem cannot be solved by increasing the transmit power because increasing transmit power for one user will also increase the interference for other users. To suppress MAI, great effort is required in the receiver [7], [8].

In this paper, we propose a multiaccess OFDM

transceiver which is approximately MAI-free so that no effort is needed to suppress MAI at the receiver. The proposed system uses the CDMA technique to separate different users, *i.e.* each user is assigned an individual signature so that it allows every user to utilize the whole bandwidth and time slots simultaneously. The proposed system is more like the first group of MC-CDMA system and, in particular, similar to the generalized MC-CDMA system [5]. However, both the MC-CDMA system and the generalized MC-CDMA system do not have the approximately MAI-free property and hence their capacity is limited by this MAI effect.

In this paper, we will derive the capacity for the proposed system and then compare it to the generalized MC-CDMA system [5]. In an eight-user Rayleigh channel environment, simulation results show the proposed system outperforms the generalized MC-CDMA system by 1 bit for SNR=1 dB and 10 bits for SNR=30 dB. One of the main advantages of the proposed system is that it tolerates certain level of asynchronous timing for every user so that it is very practical for multiaccess application. Another main advantage is that it mitigates the carrier frequency offset (CFO) problem [9] in a multiuser environment, especially when compared with orthogonal frequency-division multiple access (OFDMA) systems [18]. We will give the derived result and simulation to illustrate this point.

II. SYSTEM MODEL

The block diagram of the proposed system in the uplink direction, *i.e.* from the mobile station (MS) to the base station (BS), is shown in Fig. 1. Let M_T and M_R denote the numbers of the transmit and the receive antennas, respectively. For convenience, we assume each user has only one transmit antenna and thus there are M_T users in this case. To make the proposed system more general, we do not constrain the data symbols to be bits, *i.e.* the data symbols can be QAM or PSK.

As shown in Fig. 1, the transmitter consists of 4 stages. Suppose the input of the j th user is an $N \times 1$ vector \mathbf{x}_j , consisting of N modulation symbols. At the first stage, each symbol in \mathbf{x}_j is repeated M times and scaled to form the $NM \times 1$ vector \mathbf{y}_j . In particular

$$y_j[m + kM] = \frac{1}{\sqrt{M}}x_j[k], \quad (1)$$

where $0 \leq k \leq N - 1$ and $0 \leq m \leq M - 1$. Note that

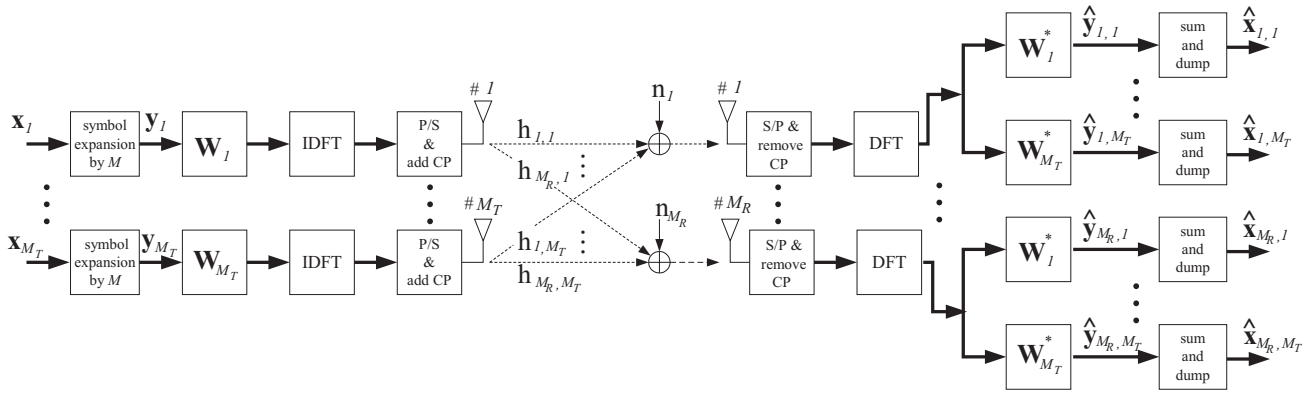

Fig. 1. The block diagram of the proposed system.

the symbol repetition parameter M should be greater or equal to the number M_T of users to maintain the orthogonality for the transmit symbols. We can choose $M = M_T$ to avoid redundancy, which will become clear later. In the following, we call the M repeated symbols “expanded symbols” and the corresponding vector \mathbf{y}_j “expanded vector” for convenience.

At the second stage, each expanded vector is passed through a diagonal scaling matrix with its diagonal elements consist of a given orthogonal code. Let $w_j[m]$ denote the m th code symbol of the orthogonal code used in the j th transmit branch. They satisfy the following property:

$$\sum_{m=0}^{M-1} w_j[m+kM]w_{j'}^*[m+kM] = \begin{cases} M, & j = j' \\ 0, & j \neq j', \end{cases} \quad (2)$$

where w^* is the conjugate of w and $0 \leq k \leq N-1$. When M is even, one example satisfying the condition of (2) is the Hadamard Walsh code. Let \mathbf{D} be an $M \times M$ Hadamard matrix [1] with column vectors $\mathbf{d}_1, \mathbf{d}_2, \dots, \mathbf{d}_M$. Then, \mathbf{W}_j is obtained by repeating \mathbf{d}_j by N times along the diagonal, *i.e.* $\mathbf{W}_j = \text{diag}(\mathbf{d}_j^T, \mathbf{d}_j^T, \dots, \mathbf{d}_j^T)$.

The last two stages of the transmitter are identical to that used in DMT systems [12]. At the third stage, each coded vector is passed through the inverse discrete Fourier transform (IDFT) matrix \mathbf{F}^\dagger , where \dagger denotes Hermitian and \mathbf{F} is the NM by NM DFT matrix given by

$$[\mathbf{F}]_{p,q} = \frac{1}{\sqrt{N \cdot M}} e^{-j \frac{2\pi}{N \cdot M} pq}, \quad (3)$$

Finally, at the fourth stage, each transformed vector is converted from parallel to serial and the cyclic prefix (CP) of length ν is added to prevent ISI, where ν is the maximum channel delay spread considered.

Let the path from the j th transmit antenna to the i th receive antenna be represented by an FIR filter of order ν , *i.e.* $\mathbf{h}_{i,j} = (h_{i,j}^{(0)}, h_{i,j}^{(1)}, \dots, h_{i,j}^{(\nu)})^T$. Then, the entire path can be represented by an $(N \cdot M + \nu) \times (N \cdot M + \nu)$

pseudo-circulant matrix of the following form [11], [14]:

$$\mathbf{H}_{i,j} = \begin{pmatrix} h_{i,j}^{(0)} & 0 & \dots & z^{-1}h_{i,j}^{(\nu)} & \dots & z^{-1}h_{i,j}^{(1)} \\ h_{i,j}^{(1)} & h_{i,j}^{(0)} & & & \ddots & \vdots \\ \vdots & h_{i,j}^{(1)} & \ddots & & & z^{-1}h_{i,j}^{(\nu)} \\ h_{i,j}^{(\nu)} & \vdots & \ddots & & & 0 \\ 0 & h_{i,j}^{(\nu)} & & & & \vdots \\ \vdots & \ddots & & \ddots & \ddots & 0 \\ 0 & \dots & 0 & \dots & h_{i,j}^{(1)} & h_{i,j}^{(0)} \end{pmatrix}. \quad (4)$$

At the receiver side, each antenna receives a data block of size $N \cdot M + \nu$. After removing the CP, each receive block is converted from serial to parallel and then passed through the discrete Fourier transform matrix (DFT). Every DFT output vector is sent to M subbranches, multiplied by \mathbf{W}^* and then passed through the block “sum and dump”. Let $\hat{\mathbf{y}}_{i,j}$ denote the reconstructed vector of \mathbf{y}_j received from the i th antenna and $\hat{\mathbf{x}}_{i,j}$ denote the output of “sum and dump”. Then the k th element of $\hat{\mathbf{x}}_{i,j}$ is given by,

$$\hat{x}_{i,j}[k] = \sum_{m=0}^{M-1} \hat{y}_{i,j}[m+kM], \quad 0 \leq k \leq N-1. \quad (5)$$

Based on $\hat{x}_{i,j}[k]$ given in (5), we may reconstruct $x_j[k]$ by combining $\hat{x}_{i,j}[k]$ for $1 \leq i \leq M_R$ using the equal gain combining (EGC) or the maximum ratio combining (MRC) technique [10].

It is easy to verify that the complexity of the proposed system is of $\mathcal{O}(N \cdot M \log(N \cdot M))$. If all transmit data are from a single user, the proposed system can be regarded as a multi-input multi-output (MIMO) system [13]. Note also that, although the block diagram in Fig. 1 is for the uplink direction, it can be modified for the downlink direction as well.

III. PERFORMANCE ANALYSIS

In this section, the performance of the proposed RCMC-CDMA system is studied. We first show that, when N is

sufficiently large, the proposed system is approximately MAI-free. Then, its capacity is derived.

A. Approximate MAI-Free Property

As shown in Fig. 1, we have the reconstructed vector \mathbf{y}_j received at the i th antenna given by

$$\hat{\mathbf{y}}_{i,j} = \mathbf{W}_j^* (\mathbf{0} \ \mathbf{F}) \left[\mathbf{H}_{i,j} \begin{pmatrix} \mathbf{F}_1^\dagger \\ \mathbf{F}_1^\dagger \end{pmatrix} \mathbf{W}_j \mathbf{y}_j + \sum_{j'=1, j' \neq j}^{M_T} \mathbf{H}_{i,j'} \begin{pmatrix} \mathbf{F}_1^\dagger \\ \mathbf{F}_1^\dagger \end{pmatrix} \mathbf{W}_{j'} \mathbf{y}_{j'} + \mathbf{n}_i \right], \quad (6)$$

where \mathbf{F}_1 is the $NM \times \nu$ submatrix of \mathbf{F} which consists of the last ν columns of \mathbf{F} and \mathbf{n}_i is the $(N \cdot M + \nu) \times 1$ noise vector received by the i th antenna. The reason to write the transmit matrix as $\begin{pmatrix} \mathbf{F}_1^\dagger \\ \mathbf{F}_1^\dagger \end{pmatrix}$ is to indicate the added CP. Similarly, the receive matrix $(\mathbf{0} \ \mathbf{F})$ is to reflect the removed CP [14]. It can be shown [15]

$$(\mathbf{0} \ \mathbf{F}) \mathbf{H}_{i,j} \begin{pmatrix} \mathbf{F}_1^\dagger \\ \mathbf{F}_1^\dagger \end{pmatrix} = \mathbf{\Lambda}_{i,j}, \quad (7)$$

where $\mathbf{\Lambda}_{i,j}$ is an $N \cdot M \times N \cdot M$ diagonal matrix whose diagonal elements are the $N \cdot M$ -point DFT of $\mathbf{h}_{i,j}$. From (7), we can rewrite (6) as

$$\hat{\mathbf{y}}_{i,j} = \mathbf{\Lambda}_{i,j} \mathbf{y}_j + \mathbf{W}_j^* \sum_{j'=1, j' \neq j}^{M_T} \mathbf{\Lambda}_{i,j'} \mathbf{W}_{j'} \mathbf{y}_{j'} + \tilde{\mathbf{n}}_i, \quad (8)$$

where $\tilde{\mathbf{n}}_i = \mathbf{W}_j^* (\mathbf{0} \ \mathbf{F}) \mathbf{n}_i$. Let us assume that \mathbf{n}_i is white Gaussian and its variance σ^2 is the same for all i . Then, $\tilde{\mathbf{n}}_i$ is also white Gaussian with variance σ^2 , since \mathbf{W}_j and \mathbf{F} are unitary matrices. From Eqn. (8), the m th symbol of $\hat{\mathbf{y}}_{i,j}$ is given by

$$\hat{y}_{i,j}[m] = \lambda_{i,j}[m] y_j[m] + \tilde{n}_i[m] + w_j^*[m] \sum_{j'=1, j' \neq j}^{M_T} \lambda_{i,j'}[m] w_{j'}[m] y_{j'}[m], \quad (9)$$

where $\lambda_{i,j}[m]$ is the m th diagonal element of $\mathbf{\Lambda}_{i,j}$. From (5) and (9), we have the k th symbol of $\hat{\mathbf{x}}_{i,j}$ given by

$$\hat{x}_{i,j}[k] = \mathcal{S}_{i,j}[k] + \mathcal{I}_{i,j}[k] + \mathcal{N}_i[k], \quad (10)$$

where $\mathcal{S}_{i,j}[k]$ is the desired signal term given by

$$\mathcal{S}_{i,j}[k] = \sum_{m=0}^{M-1} \lambda_{i,j}[m+kM] y_j[m+kM], \quad (11)$$

$\mathcal{I}_{i,j}[k]$ is the interference term given by

$$\mathcal{I}_{i,j}[k] = \sum_{m=0}^{M-1} w_j^*[m+kM] \sum_{j'=1, j' \neq j}^{M_T} \lambda_{i,j'}[m+kM] \cdot w_{j'}[m+kM] y_{j'}[m+kM], \quad (12)$$

and $\mathcal{N}_i[k]$ is the additive noise term

$$\mathcal{N}_i[k] = \sum_{m=0}^{M-1} \tilde{n}_i[m+kM]. \quad (13)$$

Note that, if data vectors $\{\mathbf{x}_1, \dots, \mathbf{x}_{M_T}\}$ are from one user, $\mathcal{I}_{i,j}[k]$ can be viewed as the inter carrier interference (ICI). On the other hand, if they are from different users, $\mathcal{I}_{i,j}[k]$ can be viewed as the MAI.

Now, consider the N -point DFT of $\mathbf{h}_{i,j}$. When N is sufficiently large, the frequency response of each subchannel is nearly flat [16]. Next, consider the $N \cdot M$ -point DFT of $\mathbf{h}_{i,j}$. When N is sufficiently large, the frequency response from index $0+kM$ to index $M-1+kM$ can be assumed to be the same and can be approximated by the k th element of the N -point DFT. In particular,

$$\lambda_{i,j}^{(N)}[k] \approx \lambda_{i,j}[m+kM], \quad 0 \leq m \leq M-1 \text{ and } 0 \leq k \leq N-1, \quad (14)$$

where $\lambda_{i,j}^{(N)}[k]$ is the k th element of the N -point DFT of $\mathbf{h}_{i,j}$. By using (1) and (14), we can rewrite (11) as

$$\mathcal{S}_{i,j}[k] \approx \sqrt{M} \lambda_{i,j}^{(N)}[k] x_j[k]. \quad (15)$$

Similarly, we can rewrite (12) as

$$\begin{aligned} \mathcal{I}_{i,j}[k] &\approx \frac{1}{\sqrt{M}} \sum_{j'=1, j' \neq j}^{M_T} \lambda_{i,j'}^{(N)}[k] x_{j'}[k] \\ &\quad \cdot \sum_{m=0}^{M-1} w_j^*[m+kM] w_{j'}[m+kM] \\ &= 0, \end{aligned} \quad (16)$$

where we use the property of the orthogonal codes in (2). From (10), (13), (15) and (16), we have

$$\hat{x}_{i,j}[k] \approx \sqrt{M} \lambda_{i,j}^{(N)}[k] x_j[k] + \sum_{m=0}^{M-1} \tilde{n}_i[m+kM]. \quad (17)$$

From (17), we see the proposed system has two major advantages when N is sufficiently large. First, the proposed system preserves the orthogonality approximately. If there is no additive noise, $x_j[k]$ can be approximately reconstructed through multiplying $\hat{x}_{i,j}[k]$ by $(\sqrt{M} \lambda_{i,j}^{(N)}[k])^{-1}$.

Second, from (16), we observe that the system is free from MAI approximately. Hence, the increase of transmit power to improve the performance for one user does not lead to significant degradation for others. This is in contrast with other MC-CDMA systems mentioned in Section 1, where increasing transmit power for one user affects other users considerably. In fact, if the MC-CDMA system [2] spreads one bit to NM chips using the orthogonal code defined in (2) and modulates each of the NM subcarriers with each chip, it shall be approximately MAI free, too. Its MAI may even be lower than that of the proposed system. However, its capacity is also lower than that of the proposed system since it transmits one symbol per block while the proposed system transmits N symbols per block.

B. Capacity Analysis

From (17), we obtain the variance of $\hat{x}_{i,j}[k]$ as

$$\sigma_{\hat{x}_{i,j}}^2[k] \approx M\sigma_{x_j}^2[k] \left| \lambda_{i,j}^{(N)}[k] \right|^2 + M\sigma^2. \quad (18)$$

By using MRC [10] to combine $\hat{\mathbf{x}}_{i,j}$, $1 \leq i \leq M_R$, we can show that the capacity of the proposed system is equal to

$$C_{M_R, M_T} \approx \frac{1}{M} \frac{1}{N} \sum_{j=1}^{M_T} \sum_{k=0}^{N-1} \log \left(1 + \frac{\sigma_{x_j}^2[k] \sum_{i=1}^{M_R} \left| \lambda_{i,j}^{(N)}[k] \right|^2}{\sigma^2} \right), \quad (19)$$

where the factor M^{-1} is due to the fact that the rate at the transmit output is M times of the rate at the transmit input. Note that the unit of (19) is bit/sec/Hz.

When N is not large enough, one can derive the capacity with interference based on (10), (11), (12) and (13):

$$\tilde{C}_{M_R, M_T} = \frac{1}{M} \frac{1}{N} \sum_{j=1}^{M_T} \sum_{k=0}^{N-1} \log \left(1 + \sum_{i=1}^{M_R} \frac{\sigma_{S_{i,j}}^2[k]}{\sigma_{\mathcal{I}_{i,j}}^2[k] + \sigma_{\mathcal{N}_i}^2[k]} \right), \quad (20)$$

where it is assumed that data vectors $\{\mathbf{x}_1, \dots, \mathbf{x}_{M_T}\}$ are independent of each other so that the desired signal term is independent of the interference term. The capacity in (19) and (20) can be achieved by power distribution according to the water-filling theory [17].

Intrinsically, the proposed RCMC-CDMA system uses the CDMA technique to separate individual users. Furthermore, it repeats the data symbols in the frequency domain to achieve approximately MAI-free property.

IV. OTHER PROPERTIES OF RCMC-CDMA SYSTEMS

In this section, we will point out two additional advantages of the RCMC-CDMA system.

A. Asynchronous Timing Effect between Users

In the uplink communication, it is difficult to guarantee that the timing of every user is perfectly synchronized. In this section, we will show that the RCMC-CDMA system allows certain level of timing mismatch among users. If the j th user has a time delay τ , where τ can be a fraction of an integer, it will cause a phase shift in the frequency domain. The phase shifted version of $\hat{y}_{i,j}[m]$ is given by

$$\hat{y}_{i,j}^\tau[m] = \hat{y}_{i,j}[m] e^{-j\theta_\tau[m]}, \quad 0 \leq m \leq NM - 1, \quad (21)$$

where $\theta_\tau[m] = \frac{2\pi}{NM} m\tau$. To maintain the approximately MAI-free property, the M phase shifts of $\hat{y}_{i,j}^\tau[kM]$, \dots , $\hat{y}_{i,j}^\tau[M-1+kM]$ should be approximately the same for each k , with $0 \leq k \leq N-1$. Without loss of generality, let $k=0$. The phase difference between $\hat{y}_{i,j}^\tau[0]$ and $\hat{y}_{i,j}^\tau[M-1]$ is given by

$$\theta_\tau[M-1] - \theta_\tau[0] = \frac{2\pi}{NM} (M-1)\tau \approx 2\pi \frac{\tau}{N}.$$

If $\frac{\tau}{N} \ll 1$, the phase difference is small so that we can assume the phase shifts between $\hat{y}_{i,j}^\tau[0]$, \dots , $\hat{y}_{i,j}^\tau[M-1]$

are approximately the same. Similarly, we can prove that the small phase shift holds for $1 \leq k \leq N-1$. Thus, if τ satisfies $\frac{\tau}{N} \ll 1$, the effect of timing mismatch can be tolerated and the RCMC-CDMA system is still approximately MAI-free.

B. Carrier Frequency Offset

In this subsection, we will explain how the RCMC-CDMA system can mitigate the CFO effect [9], which occurs in most OFDM and OFDMA systems. The CFO problem is easier to solve in single-user OFDM systems than in multiuser OFDM systems, *i.e.* OFDMA systems. Moose [9] proposed a method that successfully estimates the CFO by sending repeated data symbols. However, in OFDMA systems, each user has his/her own CFO and it could be difficult to distinguish the individual CFO. An interesting OFDMA system which uniformly allocates subchannels to users to achieve the maximum frequency diversity is called Uniform-OFDMA for short [18]. One can show that the capacity of Uniform-OFDMA is the same as that given by (19). Thus, the Uniform-OFDMA is an MAI-free system and theoretically outperforms the proposed RCMC-CDMA system. However, among OFDMA systems, the Uniform-OFDMA is the one that is most sensitive to the CFO effect due to its uniform subchannel distribution.

In RCMC-CDMA systems, we will see that even if every user suffers from CFO, the MAI caused by all other users will remain roughly unchanged as M increases. If the MAI stay in a tolerated level, every user only needs to overcome his own CFO effect. In other words, the CFO problem may be simplified from the multiuser case to the single user case in RCMC-CDMA systems. This makes CFO much less a problem in RCMC-CDMA.

To be more specific, let the MAI in $\hat{y}_{i,j}[m]$ contributed by the j' th user be denoted by $e_{i,j \leftarrow j'}[m]$. From (9), we have

$$e_{i,j \leftarrow j'}[m] = w_j^*[m] \lambda_{i,j'}[m] y_{j'}[m] w_{j'}[m].$$

Let the relative CFO in the j' th user be $\epsilon_{j'}$. It can be shown that $e_{i,j \leftarrow j'}[m]$ can be modified as [9]

$$\begin{aligned} e_{i,j \leftarrow j'}^{CFO}[m] &= w_j^*[m] \sum_{n=0}^{NM-1} \frac{1}{NM} \sum_{l=0}^{NM-1} \lambda_{i,j'}[l] y_{j'}[l] \\ &\quad \cdot w_{j'}[l] e^{\frac{2\pi}{NM} (l-m+\epsilon_{j'})n} \\ &= e_{i,j \leftarrow j'}^{AMP}[m] + e_{i,j \leftarrow j'}^{ICI}[m], \end{aligned} \quad (22)$$

where $e_{i,j \leftarrow j'}^{AMP}[m]$ is the distorted amplitude term [9]

$$e_{i,j \leftarrow j'}^{AMP}[m] = \alpha_{j'} w_j^*[m] \lambda_{i,j'}[m] y_{j'}[m] w_{j'}[m], \quad (23)$$

and $e_{i,j \leftarrow j'}^{ICI}[m]$ is the ICI between the expanded symbols

$$\begin{aligned} e_{i,j \leftarrow j'}^{ICI}[m] &= \beta_{j'} w_j^*[m] \sum_{l=0, l \neq m}^{NM-1} \lambda_{i,j'}[l] y_{j'}[l] w_{j'}[l] \\ &\quad \cdot \frac{e^{-j\pi \frac{l-m}{NM}}}{NM \sin \frac{\pi(l-m+\epsilon_{j'})}{NM}}, \end{aligned} \quad (24)$$

where $\alpha_{j'}$ and $\beta_{j'}$ are given by

$$\alpha_{j'} = \frac{\sin \pi \epsilon_{j'}}{NM \sin \frac{\pi \epsilon_{j'}}{NM}} e^{j\pi \epsilon_{j'} \frac{NM-1}{NM}},$$

and

$$\beta_{j'} = \sin \pi \epsilon_{j'} e^{j\pi \epsilon_{j'} \frac{NM-1}{NM}}.$$

From (5) and (22), we have the MAI in $\hat{x}_{i,j}[k]$ contributed by the j' 'th user given by

$$MAI_{i,j \leftarrow j'}^{CFO}[k] = \sum_{m=0}^{M-1} e_{i,j \leftarrow j'}^{AMP}[m+kM] + \sum_{m=0}^{M-1} e_{i,j \leftarrow j'}^{ICI}[m+kM]. \quad (25)$$

Let us look at the first term in (25). Using the approximation in (14), we have

$$\begin{aligned} \sum_{m=0}^{M-1} e_{i,j \leftarrow j'}^{AMP}[m+kM] &\approx \frac{\alpha_{j'}}{\sqrt{M}} \lambda_{i,j'}^{(N)}[k] x_{j'}[k] \sum_{m=0}^{M-1} w_j^*[m] w_{j'}[m] \\ &= 0. \end{aligned} \quad (26)$$

As given in (26), the distorted amplitudes which may contribute the most MAI in other systems can be approximated to be zero in the RCMC-CDMA system. Similarly, we can show that the second term in (25) can be approximated by

$$\begin{aligned} \sum_{m=0}^{M-1} e_{i,j \leftarrow j'}^{ICI}[m+kM] &\approx \frac{\beta_{j'}}{\sqrt{M}} \sum_{f=0}^{N-1} \lambda_{i,j'}^{(N)}[f] x_{j'}[f] \\ &\cdot \sum_{v=0}^{M-1} \sum_{u=0, u \neq v+(k-f)M}^{M-1} \frac{e^{-j\pi \frac{u-v+(k-f)M}{NM}}}{NM \sin \frac{\pi(u-v+(k-f)M+\epsilon_{j'})}{NM}} \\ &\cdot w_{j'}[u] w_j^*[v]. \end{aligned} \quad (27)$$

Since $u \neq v + (k-f)M$, $\sin \frac{\pi(1+\epsilon_{j'})}{NM}$ is the minimum that (u, v, k, f) can achieve when $\epsilon_{j'} < 0$ and $\sin \frac{\pi(-1+\epsilon_{j'})}{NM}$ is the minimum that (u, v, k, f) can achieve when $\epsilon_{j'} > 0$. When $k = f$, there are $M-1$ pairs of (u, v) that can make the sine function in (27) achieve $\sin \frac{\pi(1+\epsilon_{j'})}{NM}$ and $M-1$ pairs of (u, v) that make the sine function achieve $\sin \frac{\pi(-1+\epsilon_{j'})}{NM}$. On the other hand, when $f = k+1$ or $f = k-1$, both of the two situations have only 1 pair of (u, v) that make the sine function achieve $\sin \frac{\pi(1+\epsilon_{j'})}{NM}$ and 1 pair of (u, v) achieving $\sin \frac{\pi(-1+\epsilon_{j'})}{NM}$. Therefore, the term when $f = k$ contributes the most in Eqn (27). We can further show that (27) can be rewritten as

$$\begin{aligned} \sum_{m=0}^{M-1} e_{i,j \leftarrow j'}^{ICI}[m+kM] &\approx \frac{\beta_{j'}}{\sqrt{M}} \lambda_{i,j'}^{(N)}[k] x_{j'}[k] \\ &\cdot \sum_{p=1}^{M-1} \frac{e^{-j\pi \frac{p}{NM}}}{NM \sin \frac{\pi(p+\epsilon_{j'})}{NM}} \\ &\cdot \underbrace{\sum_{p=0}^{M-1-p} w_{j'}[p+q] w_j^*[q] - w_{j'}[q] w_j^*[p+q]}_{\text{orthogonal code part}} \\ &+ \text{other terms for } f \neq k. \end{aligned} \quad (28)$$

As given in (28), if the orthogonal code part equals zero, there is only the terms for $f \neq k$ left and they are relatively not so significant. An example that can achieve this goal is using only $M/2$ of the M Hadamard Walsh codes that are either symmetric or asymmetric. That is, either choosing the $M/2$ code words that are all symmetric or choosing the $M/2$ code words that are all asymmetric from the M Hadamard Walsh code words. Although this method decreases the number of users from M to $M/2$, it makes the system approximately MAI free in the CFO environments. Thus, every user only needs to deal with his/her own CFO problem.

V. SIMULATION RESULTS

Example 1. MAI-free and Capacity Performance

We compare the overall capacity of all users between the RCMC-CDMA system and the generalized MC-CDMA system [5]. For convenience, we call the RCMC-CDMA system that assumes subchannels to be flat and ignores the interference "RCMC-CDMA/xI" for short. Similarly, we name the RCMC-CDMA system that considers the interference "RCMC-CDMA/wI" for short. We assume the transmitters use the flat power distribution, which is widely adopted in DMT systems to determine the achievable data rate [19]. When the transmit power is sufficiently high, the loss in the achievable data rate is negligible without optimizing the transmit power distribution [12].

The simulation parameters are chosen as follows. The symbol rates at the transmit output for both generalized MC-CDMA and RCMC-CDMA are set to be the same. Thus, the required bandwidth is the same. $M_T = M = 8$, $M_R = 2$ and the Hadamard Walsh code is used. Each channel path has $\nu = 4$ and the path components are i.i.d. Rayleigh random variables with phase uniformly distributed in $[0, 2\pi]$. The SNR is defined as σ_x^2/σ^2 .

First, let us consider the case $N = 64$. The flat input capacity of generalized MC-CDMA without MAI suppression, RCMC-CDMA/wI and RCMC-CDMA/xI are shown in Fig. 2. Note that the dash line can be regarded as an upper bound for the RCMC-CDMA system. We observe RCMC-CDMA/wI outperforms generalized MC-CDMA by 1 bit when SNR=1 dB and by 7 bits when SNR=30 dB. The capacity of generalized MC-CDMA does not improve when SNR increases since it is not MAI-free in frequency selective environment. Thus, increasing SNR also increases MAI. Note that, although the performance of generalized MC-CDMA can be improved by MAI suppression, it demands extra complexity in the receiver.

Next, let us examine the interference effect. We observe the capacity difference between RCMC-CDMA/xI and RCMC-CDMA/wI is about 2 bits when SNR is 30 dB. This is a reasonable result since when N is not sufficiently large, the interference in (16) cannot be assumed to be zero, and it increases as the transmit power increases. To get more insight into how the increase of N can affect the approximation in (16), let us consider the case when

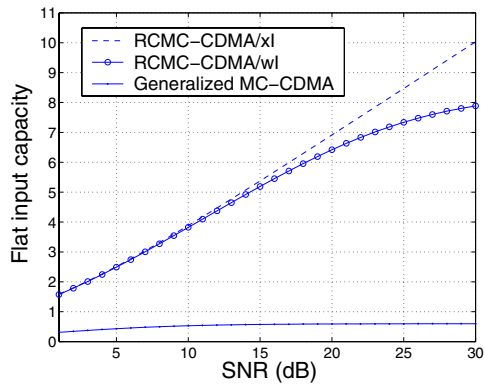

Fig. 2. The flat input capacity of generalized MC-CDMA and RCMC-CDMA systems with $M_T = 8$, $M_R = 2$ and $N = 64$.

$N = 128$. Using the same parameters above except changing N from 64 to 128, the performance is shown in Fig. 3. When SNR=30 dB, the gap is reduced from 2 bits to 1 bit as N increases from 64 to 128. This result corroborates our derivation that the interference will approach zero when N is sufficiently large.

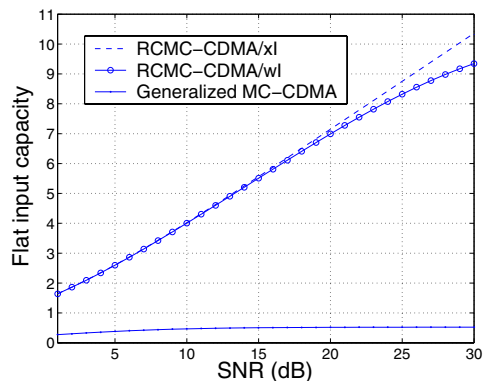

Fig. 3. The flat input capacity of generalized MC-CDMA and RCMC-CDMA systems with $M_T = 8$, $M_R = 2$ and $N = 128$.

Example 2. Relation between MAI and user number

Here, we describe the relation between MAI and the number of users when CFO appears. Let the orthogonal code be the Hadamard Walsh code. Let $M = M_T$, $M_R = 1$ and $N = 8$. Moreover, let all the paths be ideal channels and the transmit symbols be BPSK. Every user is assigned a CFO either $+\epsilon$ or $-\epsilon$ randomly. Fig. 4 shows the normalized MAI power received by the first user, *i.e.* the MAI received per data symbol and contributed by a single other user. We observe that, as M increases, the normalized MAI decreases and we expect that the overall MAI per symbol from all other $M - 1$ users stays roughly the same as M increases. We observe that when CFO is 40% and $M = 128$, the overall MAI power per symbol from all other users is about 0.55. When compared to the unit transmit power of BPSK, we may still have ability to estimate the CFO for the first user.

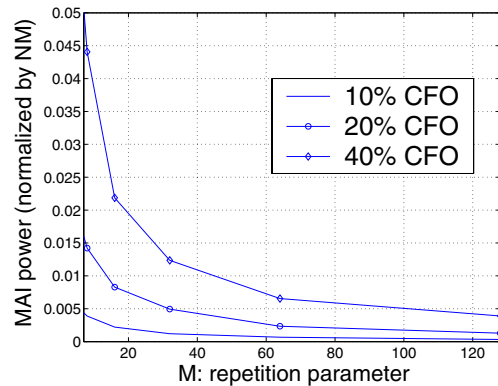

Fig. 4. Relation between normalized MAI and M .

REFERENCES

- [1] S. Verdu, *Multiuser Detection*, Cambridge Univ. Press, 1998.
- [2] N. Yee, J. P. Linnartz and G. Fettweis, "Multi-carrier CDMA in indoor wireless radio networks," *Proc. PIMRC*, 1993.
- [3] Shinsuke Hara and Ramjee Prasad, "Overview of multicarrier CDMA," *IEEE Communications Magazine*, Dec. 1998.
- [4] A. Chouly, A. Brajal and S. Jourdan "Orthogonal multicarrier techniques applied to direct sequence spread spectrum CDMA systems," *IEEE GlobCom*, vol. 3, 1993.
- [5] X. Gui, T. S. Ng, "Performance of asynchronous orthogonal multicarrier CDMA system in frequency selective fading channel," *IEEE Trans. Communications*, vol. 47, Jul. 1999.
- [6] S. Kondo and L. B. Milstein, "Performance of multicarrier DS CDMA systems," *IEEE Trans. Comm.*, vol. 44, Jul. 1996.
- [7] L. Fang and L. B. Milstein "Successive interference cancellation in multicarrier DS/CDMA," *IEEE Trans. Communications*, vol. 48, Sep. 2000.
- [8] A. Dekorsy, V. Kühn and K.-D. Kammeyer "Exploiting time and frequency diversity by iterative decoding in OFDM-CDMA systems," *IEEE GlobCom*, vol. 5, 1999.
- [9] P. H. Moose, "A technique for orthogonal frequency division multiplexing frequency offset correction," *IEEE Trans. Communications*, vol. 42, Oct. 1994.
- [10] T. S. Rappaport, *Wireless Communications*, Prentice Hall PTR, 2002.
- [11] P. P. Vaidyanathan, *Multirate Systems and Filter Banks*, Prentice Hall PTR, Englewood Cliffs, New Jersey, 1993.
- [12] J. S. Chow, J. C. Tu, J. M. Cioffi, "A discrete multitone transceiver system for HDSL applications," *IEEE Journal on Selected Areas in Communications*, vol. 9, Aug. 1991.
- [13] G. G. Raleigh and J. M. Cioffi, "Spatio-temporal coding for wireless communication," *IEEE Trans. Comm.*, vol. 46, Mar. 1998.
- [14] Y. P. Lin and S. M. Phoong, "Perfect discrete multitone modulation with optimal transceivers," *IEEE Trans. Signal Processing*, vol. 48, Jun. 2000.
- [15] R. M. Gray, "On the asymptotic eigenvalue distribution of Toeplitz matrices," *IEEE Trans. Information Theory*, vol. 18, Nov. 1972.
- [16] J. A. C. Bingham, "Multicarrier modulation for data transmission: an idea whose time has come," *IEEE Communications Magazine*, May 1990.
- [17] T. M. Cover and J. A. Thomas, *Elements of Information Theory*, John Wiley & Sons, Inc., 1991.
- [18] H. Sari, Y. Levy and G. Karam, "An analysis of orthogonal frequency division multiple access," *IEEE Globecom*, vol. 3, Nov. 1997.
- [19] *Asymmetric Digital Subscriber Line Metallic Interface Standard T1.413*, American National Standards Institute, August, 1995.